

THINBIT®

A central graphic with a black background and a blue border. At the top, the 'THINBIT' logo is displayed in white, with the 'I' containing a blue square. Below the logo, the text 'SINCE 1964' and '888-THINBIT | THINBIT.COM' is written in white. The center of the graphic features a collection of various industrial cutting tools, including grooving bits, threading bits, and turning tools, arranged in a cluster. At the bottom of the graphic, the text 'MADE IN THE USA!' is written in red and white, followed by '2025' in white. Below this, a list of services is provided in white: 'GROOVING - THREADING - PARTING - BORING - TURNING' and 'FACE GROOVING - CUSTOM TOOLING - FORM TOOLING - MILL TOOLING'.

New Products Catalog Supplement



**Proudly Made
in the U.S.A.**

Kaiser Tool Company, Inc. | 888-THINBIT

© Kaiser Tool Company, Inc. 2025

THINBIT®

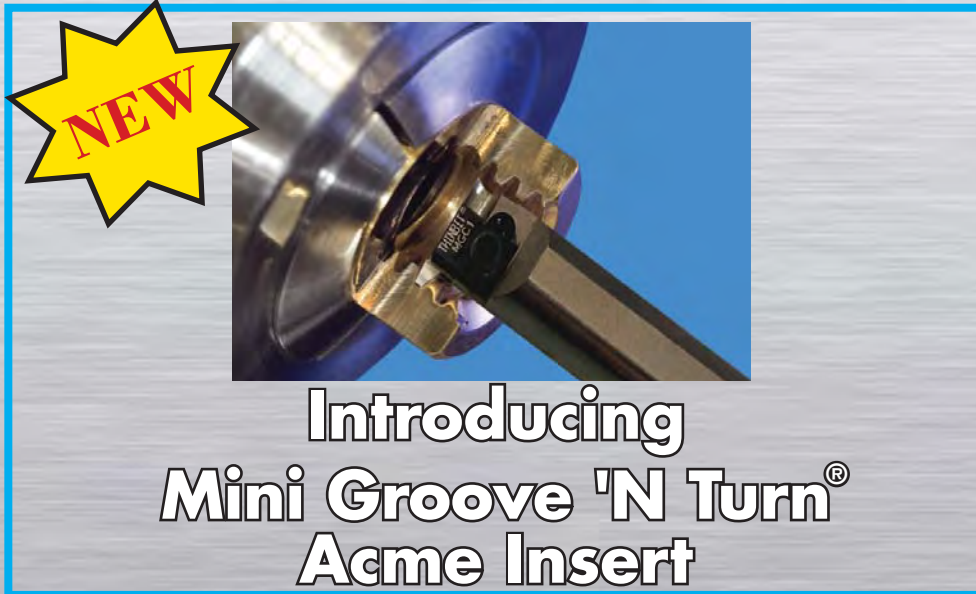

Introducing Mini Groove 'N Turn® Acme Insert

THINBIT®, from Kaiser Tool Company, presents an ACME Insert for our Mini Groove 'N Turn® line of tools.

- Internal threading for diameters .325" and larger.
- 6 Threads per inch and greater.
- Sub-micron grain DURA-MAX® 2000 and 5000 carbides.
- Inserts available coated with TiN, TiAlN, TiCN & Diamond Coating.

INCLUDED ANGLE
(TOP VIEW)



CUSTOM THREADS
(TOP VIEW)



THINBIT®

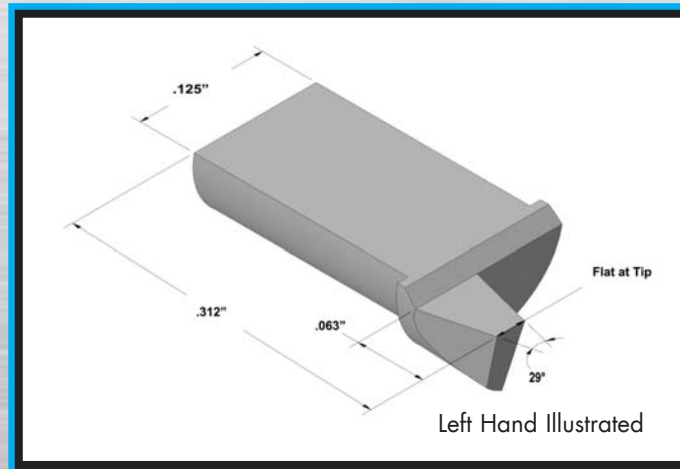

ORDERING INSTRUCTIONS

Select the **ORDER CODE** in the table below that represents your selection of orientation and insert grade.

EXAMPLE:

The **ORDER CODE** for a left hand, 8 Threads Per Inch threading insert in **DURA-MAX® 2000** with TiN coating is:
MGAT08D2LC

SPECIFICATIONS			ORDER CODE				INFO.		
Insert Orientation	Threads per Inch	Flat at Tip	Insert Grades See Page 9-5 for expanded material selections and Page 9-18 for Speeds and Feeds information		Coatings See page 9-6 for expanded coating descriptions				Toolholder Catalog Page 1-6
			DURA-MAX® 2000 Carbide For Steel & Interrupted Cutting	DURA-MAX® 5000 Carbide For Aluminum & Nonferrous	Use Uncoated Part Number and Add Coating Code				
			TIN	TICN	TAIN	Diamond		Use Toolholders Beginning With	
Left Hand	6	.057"	MGAT06D2L	MGAT06D5L	add 'C'	add 'D'	add 'E'		add 'F'
	8	.041"	MGAT08D2L	MGAT08D5L					
	10	.032"	MGAT10D2L	MGAT10D5L					
	12	.028"	MGAT12D2L	MGAT12D5L					
	14	.024"	MGAT14D2L	MGAT14D5L					
	16	.021"	MGAT16D2L	MGAT16D5L					

THINBIT[®]

Kaiser Tool Company, Inc.
3620 Centennial Drive
Fort Wayne IN 46808

Follow Us :

