

PRODUCT INFORMATION

- Internal threading for diameters .077" and larger.
- 4 threads per inch and greater.
- 1/8", 3/16", 1/4", 5/16", 3/8" and 1/2" shank.
- Short neck lengths for greater rigidity; long neck lengths for greater reach.
- Elliptically ground necks for greater strength; round necks to fit into small diameters.
- Sub-micron grain **DURA-MAX® 2000** Carbide.
- Tools can be coated with TiN, TiAlN, TiCN and Diamond coating.

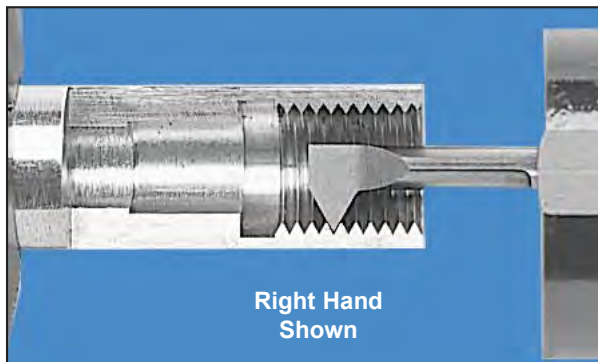

MODIFICATIONS

SEE PAGE
8-3
FOR ADDITIONAL
INFORMATION

INCLUDED ANGLE (TOP VIEW)



CUSTOM THREADS (TOP VIEW)



CUSTOM BLANK (TOP VIEW)

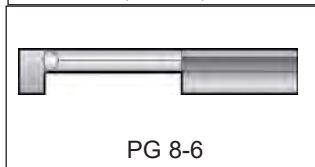

ADAPTER STYLES

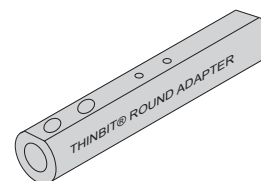

PG 7-2

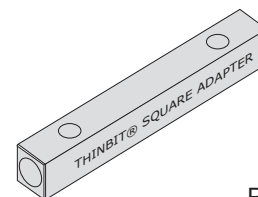

PG 7-2

TOOLHOLDER SELECTIONS

TECHNICAL SECTIONS

PRODUCT DEMONSTRATION



www.thinbit.com/qr4-3

SPEEDS AND FEEDS

PG 9-18

APPLICATION REFERENCE

PG 9-4

TROUBLESHOOTING

PG 9-7

Right Hand Illustrated

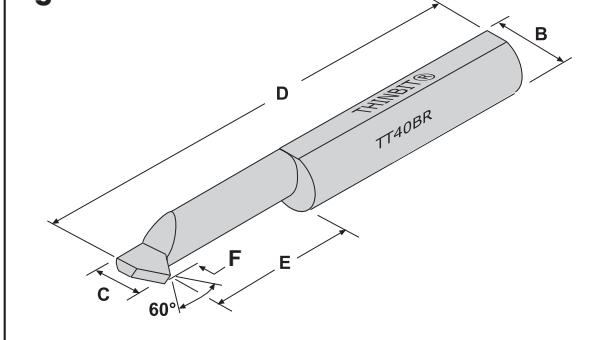

FRONT RAKE: Primary 21°

RADIUS: .002" or .000"

TOP RAKE: 0°

NOTE: Tool designed for feeding into bore only. Right hand tools should be used for right hand internal threads. Left hand tools should be used for left hand internal threads.

Select the **ORDER CODE** in the table on the next page that represents your selection of tool dimensions.

EXAMPLE:

The **ORDER CODE** for a .250" minimum bore, right hand tool for 5 to 56 T.P.I. and .620" tool reach is: **TT40BR**

KAISER TOOL COMPANY, INC.

Phone: 888-THINBIT (888-844-6248) or (260) 484-3620 • Fax: 888-THINFAX (888-844-6329) or (260) 482-1881
www.thinbit.com • General E-mail: thinbit@kaisertool.com • Orders: orders@thinbit.com • Quotes: quotes@thinbit.com

I.D. THREADING TOOLS

SPECIFICATIONS			ORDER CODE						INFORMATION			
Minimum Bore 'C'	Threads per Inch	Tool Reach 'E'	DURA-MAX® 2000 Carbide <small>See Page 9-18 for Speeds and Feeds information</small>		Coatings <small>See Page 9-6 for Expanded Coating Descriptions</small>				Overall Length 'D'	Projection 'F'	Shank Diameter 'B'	Toolholder Page 7-2 Use Toolholders Beginning With
			Minimum	Right Hand	Left Hand	TiN	TiCN	TiAlN				
.077" Round Neck	40 to 56	.291"	TT20AR	TT20AL	add 'C'	add 'D'	add 'E'	add 'F'	1.397"	.014"	1/8"	'AD'
		.416"	TT21AR	TT21AL								
	Over 56	.291"	TT20AR1	TT20AL1								
		.416"	TT21AR1	TT21AL1								
.125"	11 to 56	.312"	TT20BR	TT20BL	add 'C'	add 'D'	add 'E'	add 'F'	1.439"	.050"	1/8"	'AD'
		.437"	TT21BR	TT21BL								
	Over 56	.312"	TT20BR1	TT20BL1								
		.437"	TT21BR1	TT21BL1								
	27 to 56	.294"	TT20CR	TT20CL					1.404"	.020"		
		.419"	TT21CR	TT21CL								
	Over 56	.294"	TT20CR1	TT20CL1								
		.419"	TT21CR1	TT21CL1								
.187"	7 to 56	.454"	TT30BR	TT30BL	add 'C'	add 'D'	add 'E'	add 'F'	1.974"	.080"	3/16"	'AD'
		.704"	TT31BR	TT31BL								
	Over 56	.454"	TT30BR1	TT30BL1								
		.704"	TT31BR1	TT31BL1								
	16 to 56	.428"	TT30CR	TT30CL					1.922"	.035"		
		.678"	TT31CR	TT31CL								
Over 56	.428"	TT30CR1	TT30CL1									
	.678"	TT31CR1	TT31CL1									
.250"	5 to 56	.596"	TT40BR	TT40BL	add 'C'	add 'D'	add 'E'	add 'F'	2.508"	.110"	1/4"	'AD'
		.846"	TT41BR	TT41BL								
	Over 56	.596"	TT40BR1	TT40BL1								
		.846"	TT41BR1	TT41BL1								
	11 to 56	.562"	TT40CR	TT40CL					2.439"	.050"		
		.812"	TT41CR	TT41CL								
Over 56	.562"	TT40CR1	TT40CL1									
	.812"	TT41CR1	TT41CL1									
.313"	4 to 56	.739"	TT50BR	TT50BL	add 'C'	add 'D'	add 'E'	add 'F'	2.513"	.140"	5/16"	'AD'
		1.114"	TT51BR	TT51BL								
	Over 56	.739"	TT50BR1	TT50BL1								
		1.114"	TT51BR1	TT51BL1								
	9 to 56	.694"	TT50CR	TT50CL					2.424"	.063"		
		1.069"	TT51CR	TT51CL								
Over 56	.694"	TT50CR1	TT50CL1									
	1.069"	TT51CR1	TT51CL1									
.375"	5 to 56	.846"	TT60CR	TT60CL	add 'C'	add 'D'	add 'E'	add 'F'	2.948"	.110"	3/8"	'AD'
		1.346"	TT61CR	TT61CL								
	Over 56	.846"	TT60CR1	TT60CL1								
		1.346"	TT61CR1	TT61CL1								
.500"	4 to 56	1.119"	TT80CR	TT80CL	add 'C'	add 'D'	add 'E'	add 'F'	3.434"	.150"	1/2"	'AD'
		1.869"	TT81CR	TT81CL								
	Over 56	1.119"	TT80CR1	TT80CL1								
		1.869"	TT81CR1	TT81CL1								

I.D. TOOLS
THREADING

ROUND & SQUARE ADAPTERS

PRODUCT INFORMATION

- Designed to adapt round tooling to lathe workholding
- ID sizes 1/8", 5/32", 3/16", 1/4", 5/16" and 3/8".
- Round sizes 1/4", 3/8", 1/2", 5/8" and 3/4".
- Square sizes 5/16", 3/8", 1/2", 5/8", 3/4", 1" and 1-1/4".
- Modifications can be provided on any of our tooling. Please contact us with your application requirements.

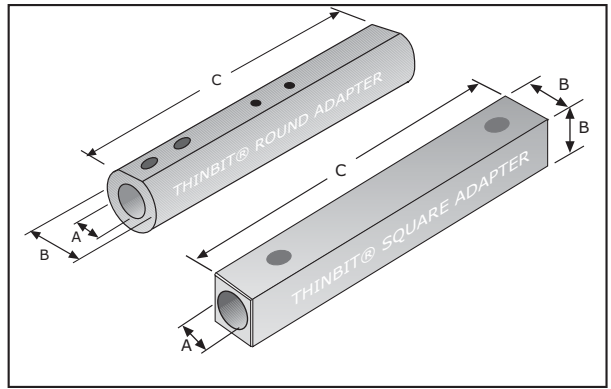

TOOL SELECTIONS

SOLID CARBIDE

- Grooving Page 1-3
- Face Grooving Page 2-3
- Boring Page 3-3
- Threading Page 4-3 & 4-5



GROOVING BARS

- Grooving Page 1-5
- Face Grooving Page 2-5

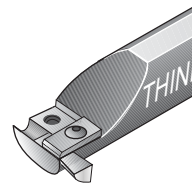

BORING BARS

- MBA Page 3-13
- MBB Page 3-15
- MBC Page 3-17
- MBE Page 3-8
- MBF Page 3-9
- MBG Page 3-10

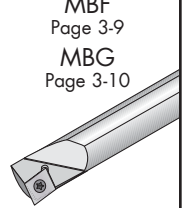

Scan this code for additional information.

www.thinbit.com/qr7-2

ORDERING INSTRUCTIONS

Select the **ORDER CODE** in the table below that represents your selection of adapter dimensions.

EXAMPLE:

The **ORDER CODE** for a .375" ID x .625" OD round adapter is:

AD3762

SPECIFICATIONS				ORDER CODE				SPECIFICATIONS				ORDER CODE			
Adapter Style	Shank Dimensions			Adapter	Replacement Parts			Adapter Style	Shank Dimensions			Adapter	Replacement Parts		
	'A'	'B'	'C'		Includes Adapter and Hardware	Screw	Wrench		Pin	'A'	'B'		'C'	Includes Adapter and Hardware	Screw
Round	.125"	.250"	3.000"	AD1225	S1402M	W0050	P0203	Round	.312"	.500"	4.000"	AD3150	S1802	W1005	P0204
				AD1237	S1402	W0050	P0203			.625"		AD3162	S1802	W1005	P0206
				AD1250	S1402	W0050	P0204			.750"		AD3175	S1802	W1005	P0206
				AD1262	S1404	W0050	P0204			1.000"		AD3110	S1804	W1005	P0206
				AD1275	S1404	W0050	P0204		.375"	.625"	AD3762	S1802	W1005	P0206	
				AD1210	S1404	W0050	P0204			.750"	AD3775	S1802	W1005	P0206	
	.156"	.375"	3.000"	AD1537	S1402M	W0050	---	.500"	.750"	4.000"	AD3710	S1804	W1005	P0206	
				AD1550	S1402	W0050	---				AD5075	S1802	W1005	P0206	
				AD1562	S1403	W0050	---				AD5010	S1804	W1005	P0206	
	.187"	.375"	3.000"	AD1837	S1402M	W0050	P0203	.750"	1.000"	4.000"	AD56	---	---	---	
				AD1850	S1802	W1005	P0204				AD38	S1802	W1005	---	
				AD1862	S1802	W1005	P0206				AD12	S1802	W1005	---	
				AD1875	S1804	W1005	P0206				AD58	S1802	W1005	---	
	.250"	.625"	4.000"	AD1810	S1404	W0050	P0206	Square	.250" & .375"	3.000"	AD34	S1802	W1005	---	
				AD2537	S1402M	W0050	P0203				AD01	S1802	W1005	---	
				AD2550	S1802	W1005	P0204				AD14	S1802	W1005	---	
				AD2562	S1802	W1005	P0206								
				AD2575	S1804	W1005	P0206								
				AD2510	S1804	W1005	P0206								

TOOLHOLDERS

KAISER TOOL COMPANY, INC.

Phone: 888-THINBIT (888-844-6248) or (260) 484-3620 • Fax: 888-THINFAX (888-844-6329) or (260) 482-1881
www.thinbit.com • General E-mail: thinbit@kaisertool.com • Orders: orders@thinbit.com • Quotes: quotes@thinbit.com