









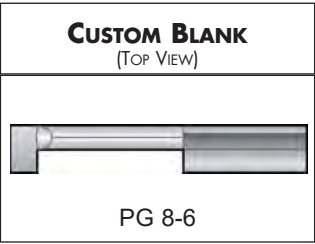

PRODUCT INFORMATION	<ul style="list-style-type: none"> • For profiling diameters .125" and larger. • 1/8", 3/16", 1/4", 5/16", 3/8" and 1/2" shank. • Elliptically ground necks for greater strength. • Sub-micron grain DURA-MAX® 2000 Carbide. • Tools available with TiN, TiAlN, TiCN and Diamond coating. 	Right Hand Profiling Tool Shown	
	Right Hand Reverse Profiling Tool Shown		

MODIFICATIONS SEE PAGE 8-3 FOR ADDITIONAL INFORMATION	CUSTOM BLANK (TOP VIEW)	RADI (TOP VIEW)	LEAD ANGLE (TOP VIEW)	BACK CLEARANCE (TOP VIEW)
	 PG 8-6			
		TOP RAKE (SIDE VIEW)	CHIP BREAKER (SIDE VIEW)	SIDE CLEARANCE (END VIEW)
				

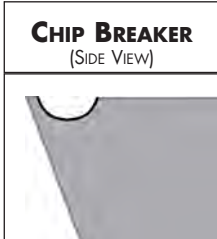
TOOLHOLDER SELECTIONS	ADAPTER STYLES	
	 PG 7-2	 PG 7-2

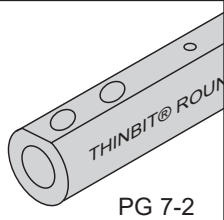
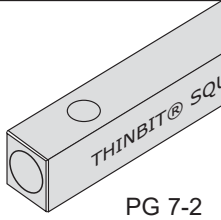
TECHNICAL SECTIONS	PRODUCT DEMONSTRATION	SPEEDS AND FEEDS	APPLICATION REFERENCE	TROUBLESHOOTING
	 www.thinbit.com/qr3-5	PG 9-15	PG 9-4	PG 9-7

ORDERING INSTRUCTIONS

Select the **ORDER CODE** in the table on the next page that represents your selection of tool dimensions.

EXAMPLE:

The **ORDER CODE** for a .375" minimum bore, right hand tool with a 1.350" tool reach and .125" projection is:
PT61CR

KAISER TOOL COMPANY, INC.

PROFILING & REVERSE PROFILING TOOLS

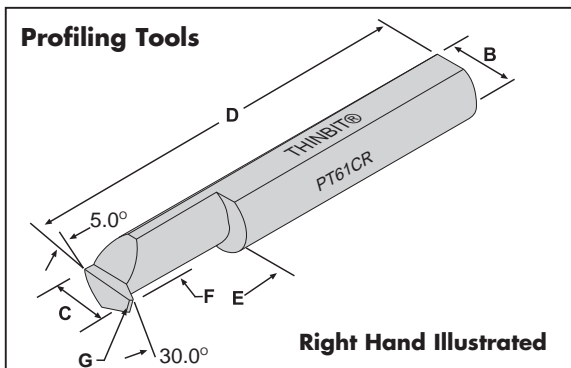

FRONT RAKE: Primary 21°
 SIDE CLEARANCE: 5° Lead side
 BACK CLEARANCE: 5° Lead side
 BACK CLEARANCE: 30° Trailing side
 NOTE: Tool designed for feeding into bore only.

SPECIFICATIONS				ORDER CODE				INFORMATION				
Minimum Bore	Tool Reach	Nose Radius	Projection	DURA-MAX® 2000 Carbide See Page 9-15 for Speeds and Feeds		Coatings See Page 9-6 for expanded coating descriptions Use uncoated part number and add coating code				Shank Diameter	Overall Length	Toolholder Page 7-2
'C'	'E'	'G'	'F'	Right Hand	Left Hand	TiN	TiCN	TiAlN	Diamond	'B'	'D'	Use Toolholders Beginning With
	Minimum		Minimum									
.125"	.425"	.007"	.052"	PT21BR	PT21BL	add 'C'	add 'D'	add 'E'	add 'F'	1/8"	1.500"	'AD'
.187"	.705"	.010"	.083"	PT31BR	PT31BL					3/16"	2.000"	'AD'
.250"	.840"	.010"	.115"	PT41BR	PT41BL					1/4"	2.500"	'AD'
.312"	1.115"	.015"	.146"	PT51BR	PT51BL					5/16"	2.500"	'AD'
.375"	1.350"	.015"	.115"	PT61CR	PT61CL					3/8"	3.000"	'AD'
.500"	1.870"	.015"	.157"	PT81CR	PT81CL					1/2"	3.500"	'AD'

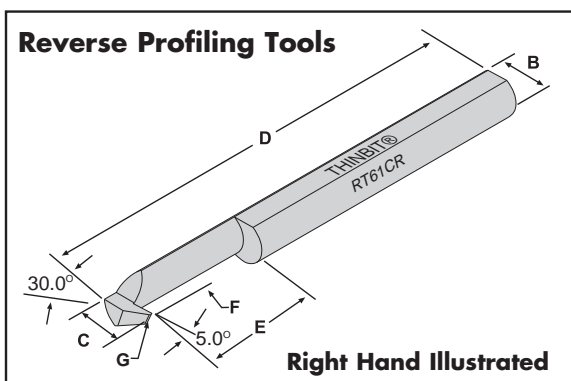

FRONT RAKE: Primary 21°
 SIDE CLEARANCE: 10° Lead side
 BACK CLEARANCE: 30° Lead side
 BACK CLEARANCE: 5° Trailing side
 NOTE: Tool designed for feeding out of bore only.

SPECIFICATIONS				ORDER CODE				INFORMATION				
Minimum Bore	Tool Reach	Nose Radius	Projection	DURA-MAX® 2000 Carbide See Page 9-15 for Speeds and Feeds		Coatings See Page 9-6 for expanded coating descriptions Use uncoated part number and add coating code				Shank Diameter	Overall Length	Toolholder Page 7-2
'C'	'E'	'G'	'F'	Right Hand	Left Hand	TiN	TiCN	TiAlN	Diamond	'B'	'D'	Use Toolholders Beginning With
	Minimum		Minimum									
.125"	.375"	.007"	.052"	RT21BR	RT21BL	add 'C'	add 'D'	add 'E'	add 'F'	1/8"	1.500"	'AD'
.187"	.625"	.010"	.083"	RT31BR	RT31BL					3/16"	2.000"	'AD'
.250"	.750"	.010"	.115"	RT41BR	RT41BL					1/4"	2.500"	'AD'
.312"	1.000"	.015"	.146"	RT51BR	RT51BL					5/16"	2.500"	'AD'
.375"	1.250"	.015"	.115"	RT61CR	RT61CL					3/8"	3.000"	'AD'
.500"	1.750"	.015"	.157"	RT81CR	RT81CL					1/2"	3.500"	'AD'

KAISER TOOL COMPANY, INC.

Phone: 888-THINBIT (888-844-6248) or (260) 484-3620 • Fax: 888-THINFAX (888-844-6329) or (260) 482-1881
 www.thinbit.com • General E-mail: thinbit@kaisertool.com • Orders: orders@thinbit.com • Quotes: quotes@thinbit.com

PROFILING

ROUND & SQUARE ADAPTERS

PRODUCT INFORMATION

- Designed to adapt round tooling to lathe workholding
- ID sizes 1/8", 5/32", 3/16", 1/4", 5/16" and 3/8".
- Round sizes 1/4", 3/8", 1/2", 5/8" and 3/4".
- Square sizes 5/16", 3/8", 1/2", 5/8", 3/4", 1" and 1-1/4".
- Modifications can be provided on any of our tooling. Please contact us with your application requirements.

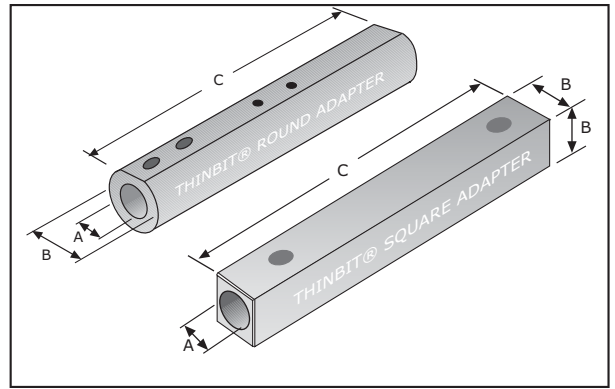

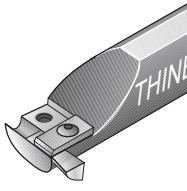
TOOL SELECTIONS	SOLID CARBIDE		GROOVING BARS		BORING BARS	
	Grooving Page 1-3 Face Grooving Page 2-3 Boring Page 3-3 Threading Page 4-3 & 4-5			Grooving Page 1-5 Face Grooving Page 2-5		MBA Page 3-13 MBB Page 3-15 MBC Page 3-17 MBE Page 3-8



Scan this code for additional information.

www.thinbit.com/qr7-2

ORDERING INSTRUCTIONS

Select the **ORDER CODE** in the table below that represents your selection of adapter dimensions.

EXAMPLE:

The **ORDER CODE** for a .375" ID x .625" OD round adapter is:
AD3762

SPECIFICATIONS				ORDER CODE				SPECIFICATIONS				ORDER CODE			
Adapter Style	Shank Dimensions			Adapter	Replacement Parts			Adapter Style	Shank Dimensions			Adapter	Replacement Parts		
	'A'	'B'	'C'		Includes Adapter and Hardware	Screw	Wrench		Pin	'A'	'B'		'C'	Includes Adapter and Hardware	Screw
Round	.125"	.250"	3.000"	AD1225	S1402M	W0050	P0203	Round	.312"	.500"	4.000"	AD3150	S1802	W1005	P0204
				AD1237	S1402	W0050	P0203			.625"		AD3162	S1802	W1005	P0206
				AD1250	S1402	W0050	P0204			.750"		AD3175	S1802	W1005	P0206
				AD1262	S1404	W0050	P0204			1.000"		AD3110	S1804	W1005	P0206
				AD1275	S1404	W0050	P0204		.375"	.625"	AD3762	S1802	W1005	P0206	
				AD1210	S1404	W0050	P0204			.750"	AD3775	S1802	W1005	P0206	
	.156"	.375"	3.000"	AD1537	S1402M	W0050	---	1.000"	AD3710	S1804	W1005	P0206			
				AD1550	S1402	W0050	---	.500"	.750"	AD5075	S1802	W1005	P0206		
				AD1562	S1403	W0050	---		1.000"	AD5010	S1804	W1005	P0206		
	.187"	.375"	3.000"	AD1837	S1402M	W0050	P0203	Square	.250"	.312"	3.000"	AD56	---	---	---
				AD1850	S1802	W1005	P0204			.375"		AD38	S1802	W1005	---
				AD1862	S1802	W1005	P0206		.250" & .375"	.500"	AD12	S1802	W1005	---	
				AD1875	S1804	W1005	P0206			.625"	AD58	S1802	W1005	---	
	AD1810	S1404	W0050	P0206	.750"	AD34	S1802		W1005	---					
	.250"	.375"	4.000"	AD2537	S1402M	W0050	P0203		1.000"	AD01	S1802	W1005	---		
				AD2550	S1802	W1005	P0204		.250" & .375"	1.250"	AD14	S1802	W1005	---	
				AD2562	S1802	W1005	P0206								
				AD2575	S1804	W1005	P0206								
				AD2510	S1804	W1005	P0206								

TOOLHOLDERS

KAISER TOOL COMPANY, INC.

Phone: 888-THINBIT (888-844-6248) or (260) 484-3620 • Fax: 888-THINFAX (888-844-6329) or (260) 482-1881
www.thinbit.com • General E-mail: thinbit@kaisertool.com • Orders: orders@thinbit.com • Quotes: quotes@thinbit.com